

# IES

Integrated Energy Systems

## DOE Office of Nuclear Energy Integrated Energy Systems: Program Overview

Shannon Bragg-Sitton, Ph.D.

Director, Integrated Energy & Storage Systems

National Technical Director, DOE-NE Integrated Energy Systems

[shannon.bragg-sitton@inl.gov](mailto:shannon.bragg-sitton@inl.gov)

INL/MIS-22-66404

March 17, 2022

# Motivation and challenges

- Evolution in the electric power sector
  - Advent of variable renewables → increased variation in net load
  - Transition away from traditional baseload resources
  - Increased need for generator flexibility while ensuring grid resilience, reliability
- Ambitious goals for deep decarbonization (“net-zero”)  
U.S. targets:
  - Zero emissions from electricity sector by 2035
  - Economy-wide net-zero emissions by 2050 → industry, transportation
- Traditional energy planning tools are often limited in applicability to new scenarios, technologies, opportunities
  - Cross-sectoral energy utilization from a single generator not represented

# Operational paradigms—nuclear energy flexibility

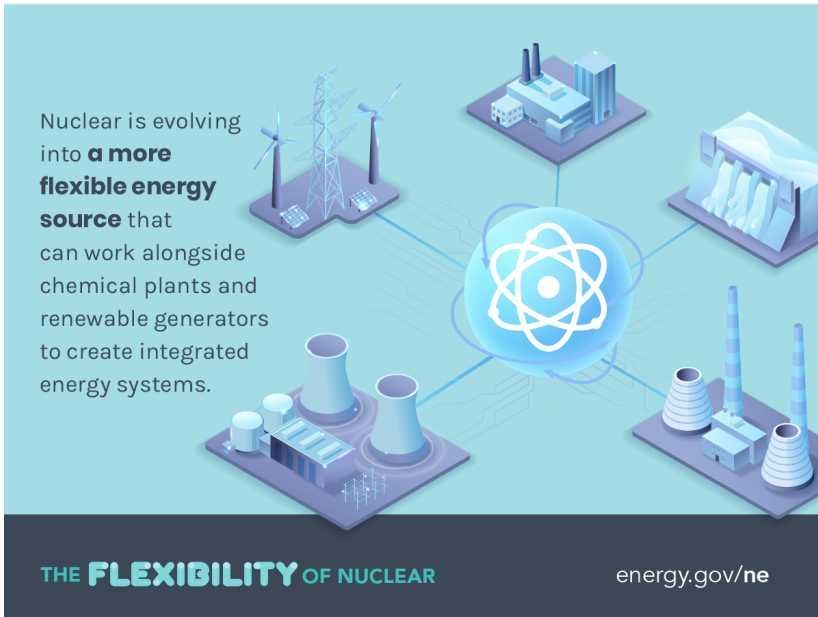

- **Operational flexibility**
- **Product flexibility**
- **Deployment flexibility**

**Nuclear flexibility is key to enabling other clean energy generators to provide deep decarbonization across multiple sectors.**

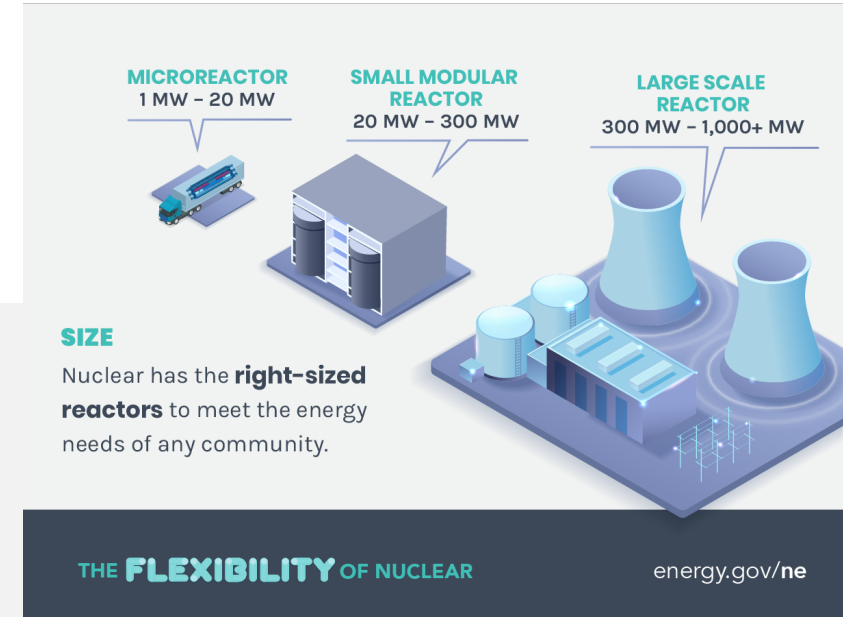
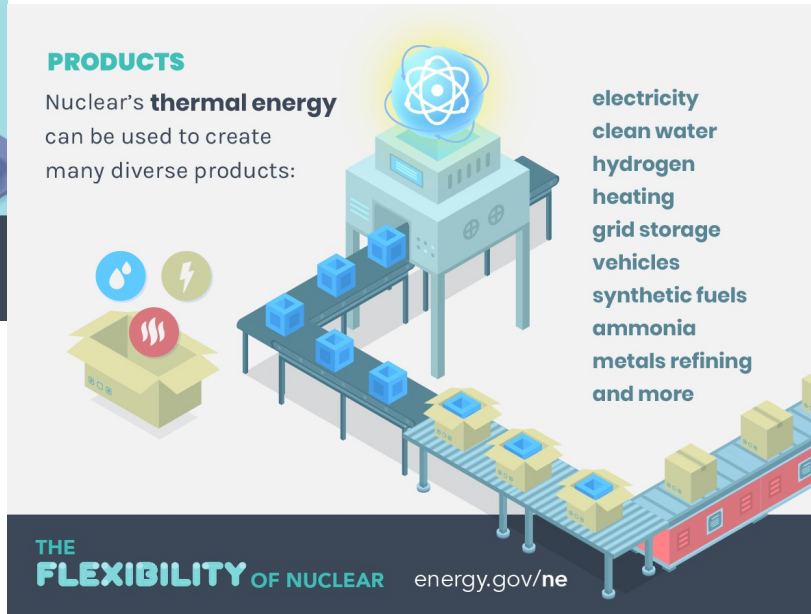

U.S. DEPARTMENT OF **ENERGY** | Office of **NUCLEAR ENERGY**



# Integrated Energy System (IES) needs: Technology advancement for energy transport, conversion, and storage

## Integrated Energy Systems Involve

- Thermal, electrical, and process intermediates integration
- More complex systems than co-generation, poly-generation, or combined heat and power
- May exploit the economics of coordinated energy systems
- May provide grid services through demand response (import or export)

## Technology Development Needs & Opportunities

- New energy storage technologies (thermal, chemical, and electrical)
- Thermo-electrical chemical conversion processes
- Modern advanced informatics and decision systems for massive data
- Embedded sensors for health monitoring
- Cyber security approaches

## Example: Nuclear-driven IES in the U.S. Midwest (notional)

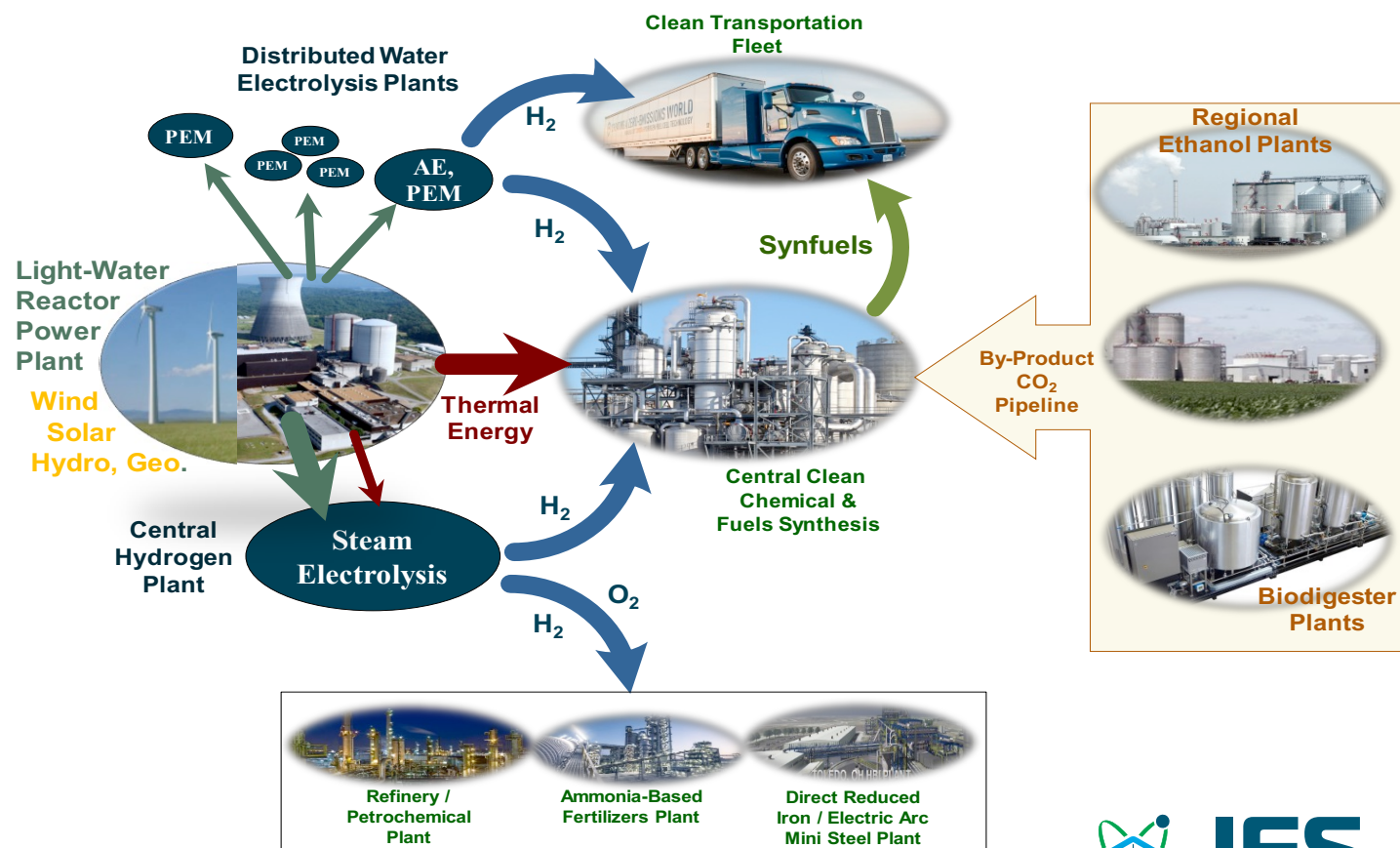

# DOE-NE R&D Programs for Multi-Output Integrated Energy Systems

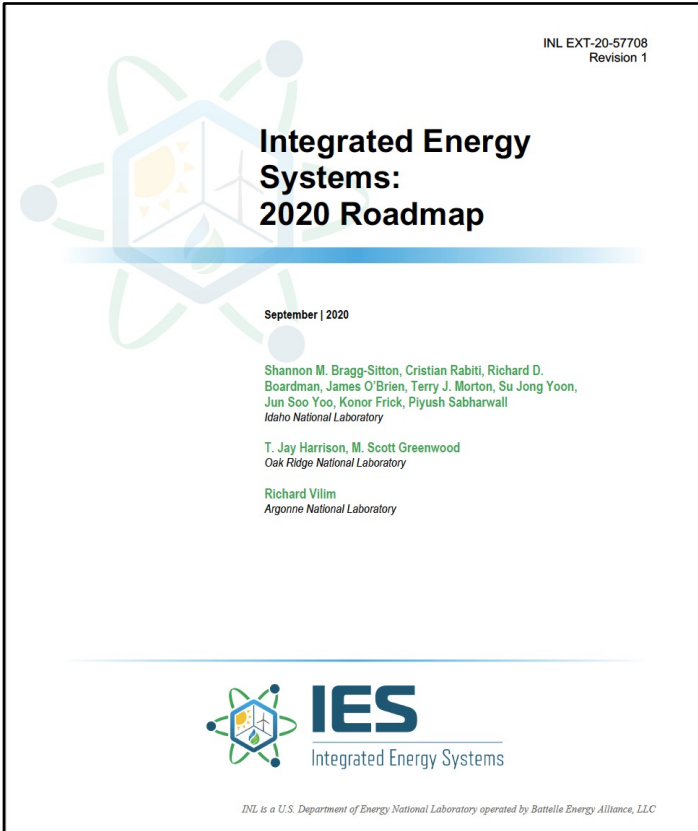

Crosscutting Technology Development  
Integrated Energy Systems



## VISION

A robust and economically viable fleet of light-water and advanced nuclear reactors available to support US clean baseload electricity needs, while also operating flexibly to support a broad range of non-electric products and grid services.

Flexible simulation ecosystem for system design, analysis, technical and economic optimization

Experimental demonstration for technology development and model validation

Greenfield system design and advanced reactor applications

Reduce risk for commercial LWR-IES deployment

Energy dispatch design and implementation

Technical and economic analysis, near-term markets

Safety assessment and licensing considerations

## Timeline for Deployment

Current fleet **NOW**—Advanced Reactors **5-15 years**



Flexible Plant Operations & Generation Pathway



# IES Program Overview

**Mission:** Maximize energy utilization, generator profitability, and grid reliability and resilience through novel systems integration and process design, using nuclear energy resources across all energy sectors in coordination with other generators on the grid.

**Vision:** A robust and economically viable fleet of light-water and advanced nuclear reactors available to support US clean baseload electricity needs, while also operating flexibly to support a broad range of non-electric products and grid services.

**Goals:** The IES program develops tools and technologies that will lead to demonstration of multiple integrated energy systems that have a clear path toward commercialization. Timelines follow the associated reactor concepts and designs (current fleet now, SMRs 1-5 yrs, non-LWR 5-15 years).

## Strategic R&D Areas (Control Accounts)

- **System Simulation.** Develop and exercise an ecosystem for modeling, analysis, optimization of IES that can accommodate various reactor types, renewable technologies, and energy users.
  - **Economic Analysis.** Establish a reference capability to validate current practices in valuing nuclear energy in the energy market (electric and non-electric).
- **Experimental Evaluation.** Establish and operate a fully-functional and diverse non-nuclear facility for model validation and initial technology demonstration.

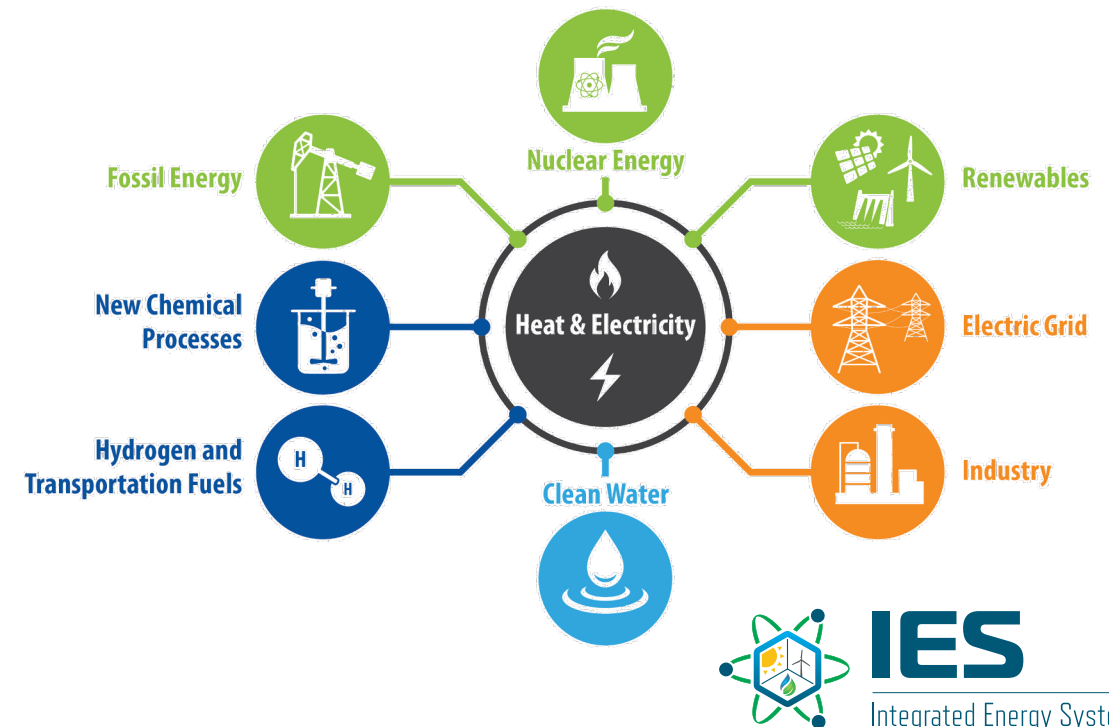

# Summary of potential nuclear-driven IES opportunities

Reactor sizes align with the needs of each application, heat augmentation can be applied if needed to match process temperature demands.

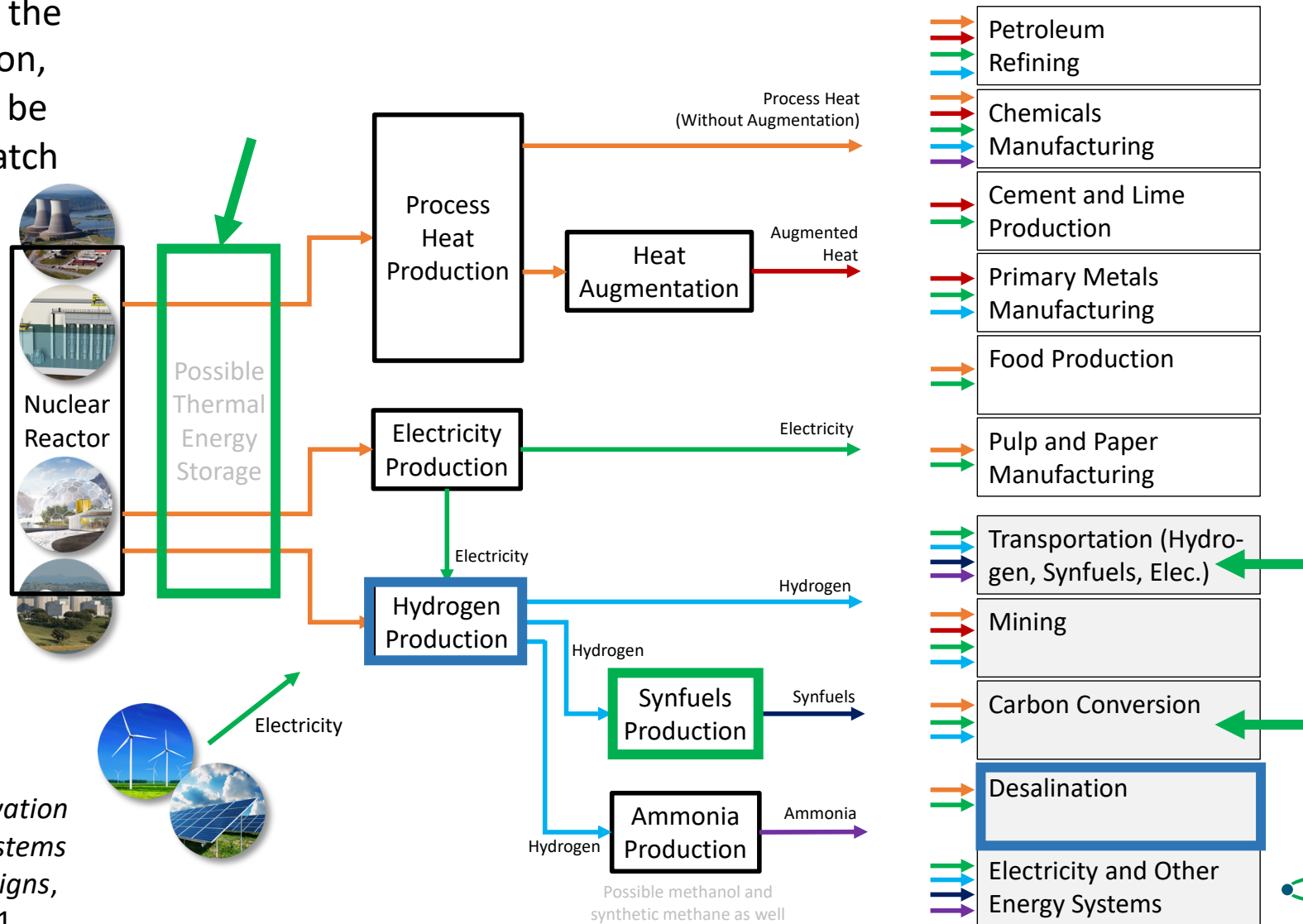

Source: INL, National Reactor Innovation Center (NRIC) Integrated Energy Systems Demonstration Pre-Conceptual Designs, INL EXT-21-61413, Rev. 1, April 2021

# IES M&S Tools: Purpose

- Technoeconomic Assessment Analyses for IES
  - Portfolio Optimization
  - Dispatch Optimization
  - Process Model Simulation
  - Economic Analysis
  - Supervisory Control
  - Stochastic Analysis
  - Workflow Automation

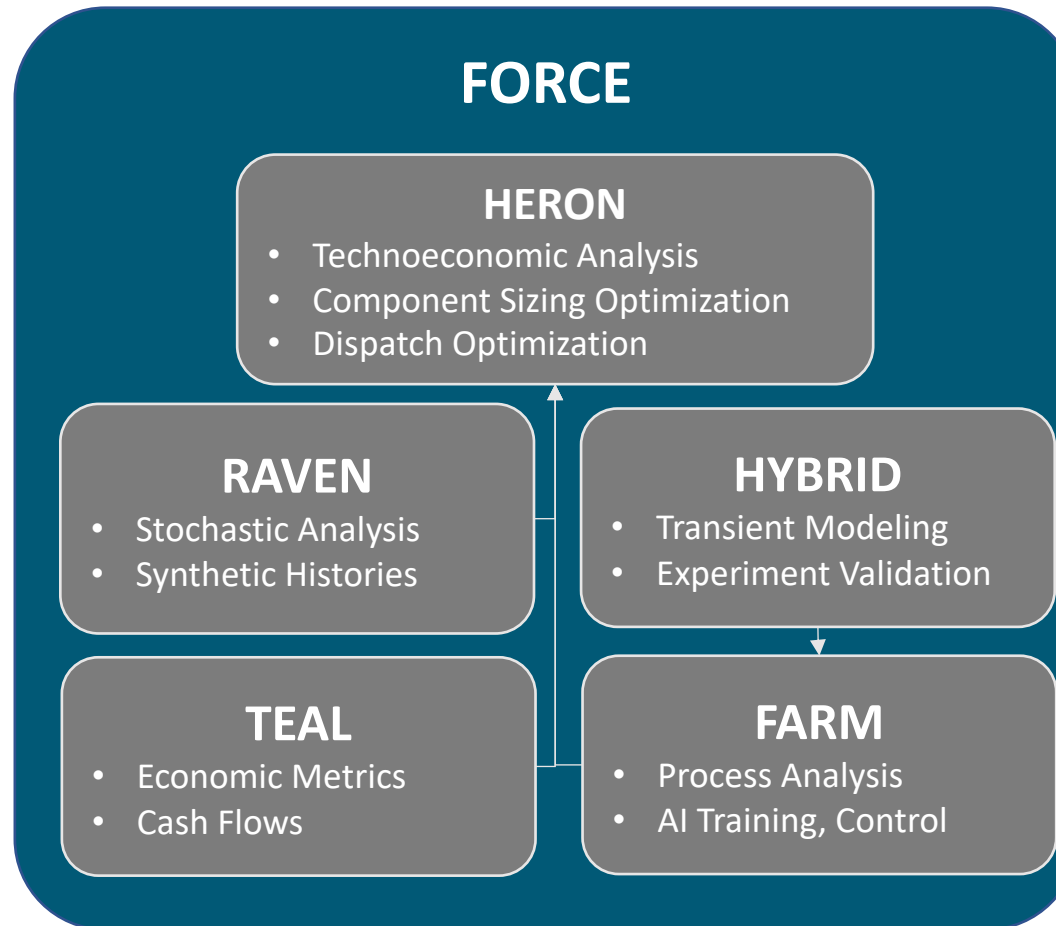



# APS Case Study 2019 – Desalination

# Arizona Public Service (APS) challenge

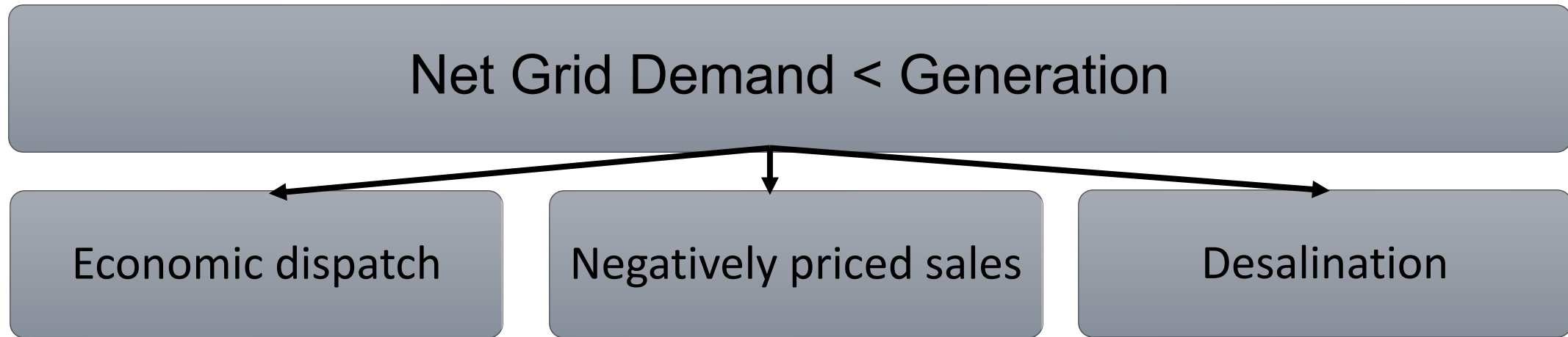

- "Classic" considerations:
  - Wear and tear of plant component (difficult to determine)
  - Negligible variable costs, e.g., fuel cost (true?)
  - Electric grid price will be negative (how to assess this?)
- Another option: **Desalination**
  - Change in water procurement costs
  - Other lower cost water sources available (brackish water)

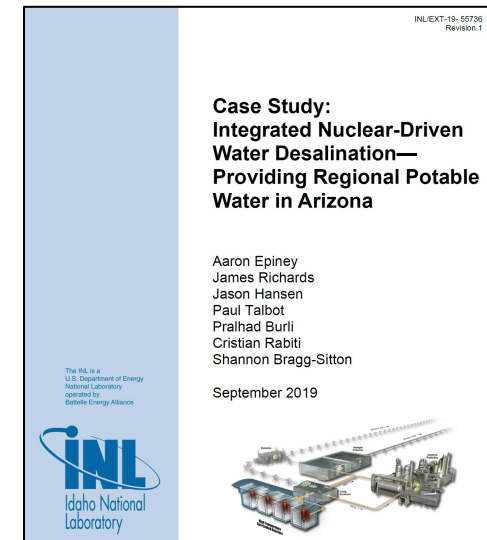

# Potential Scenarios

## Case 0: Status Quo

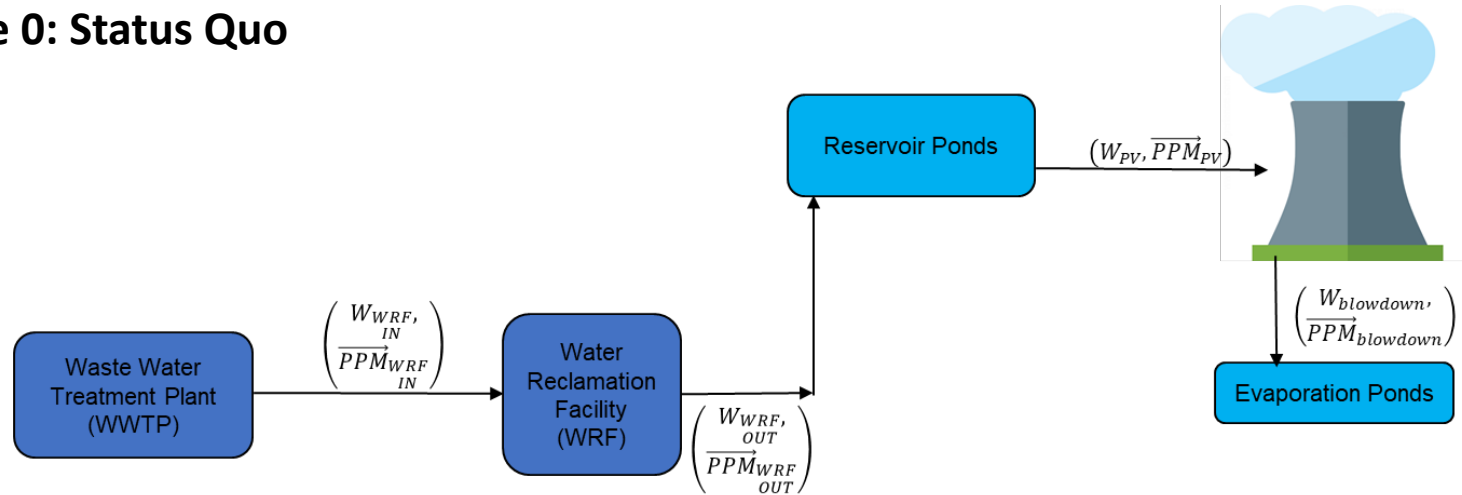

## Case 1: Desalination for Plant Cooling

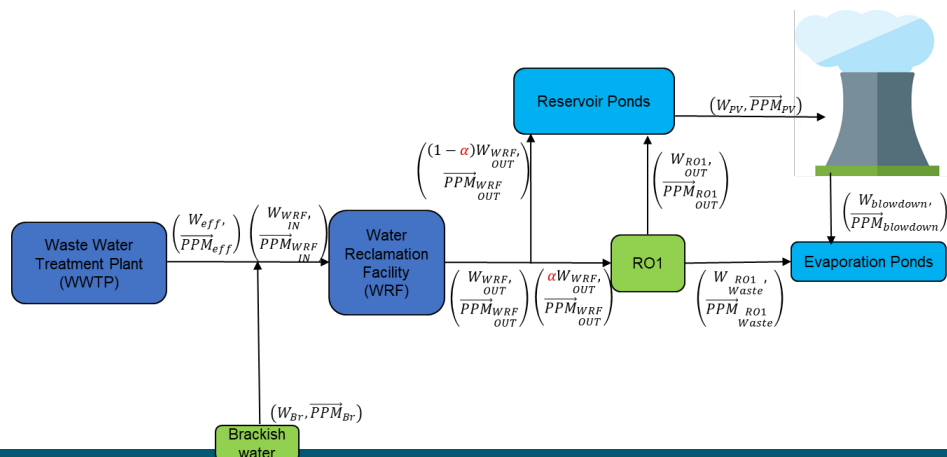

## Case 2: Desalination for Plant Cooling plus Potable Water

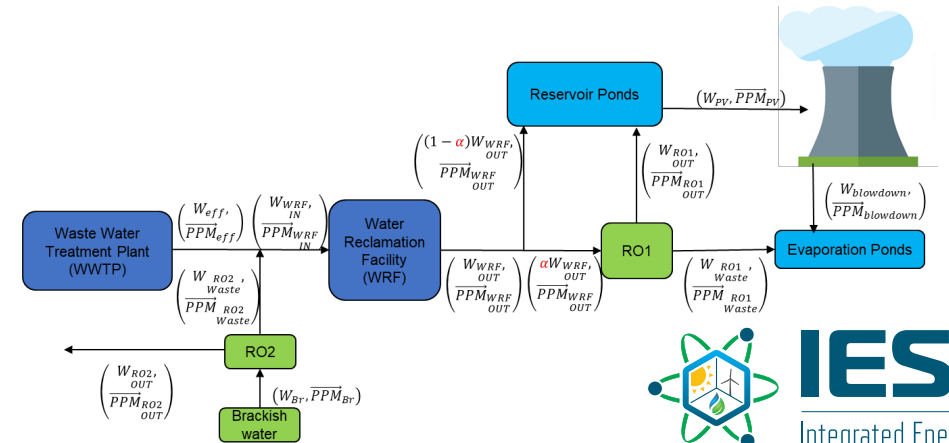

# Potential Scenarios

## Case 1: Desalination for Plant Cooling

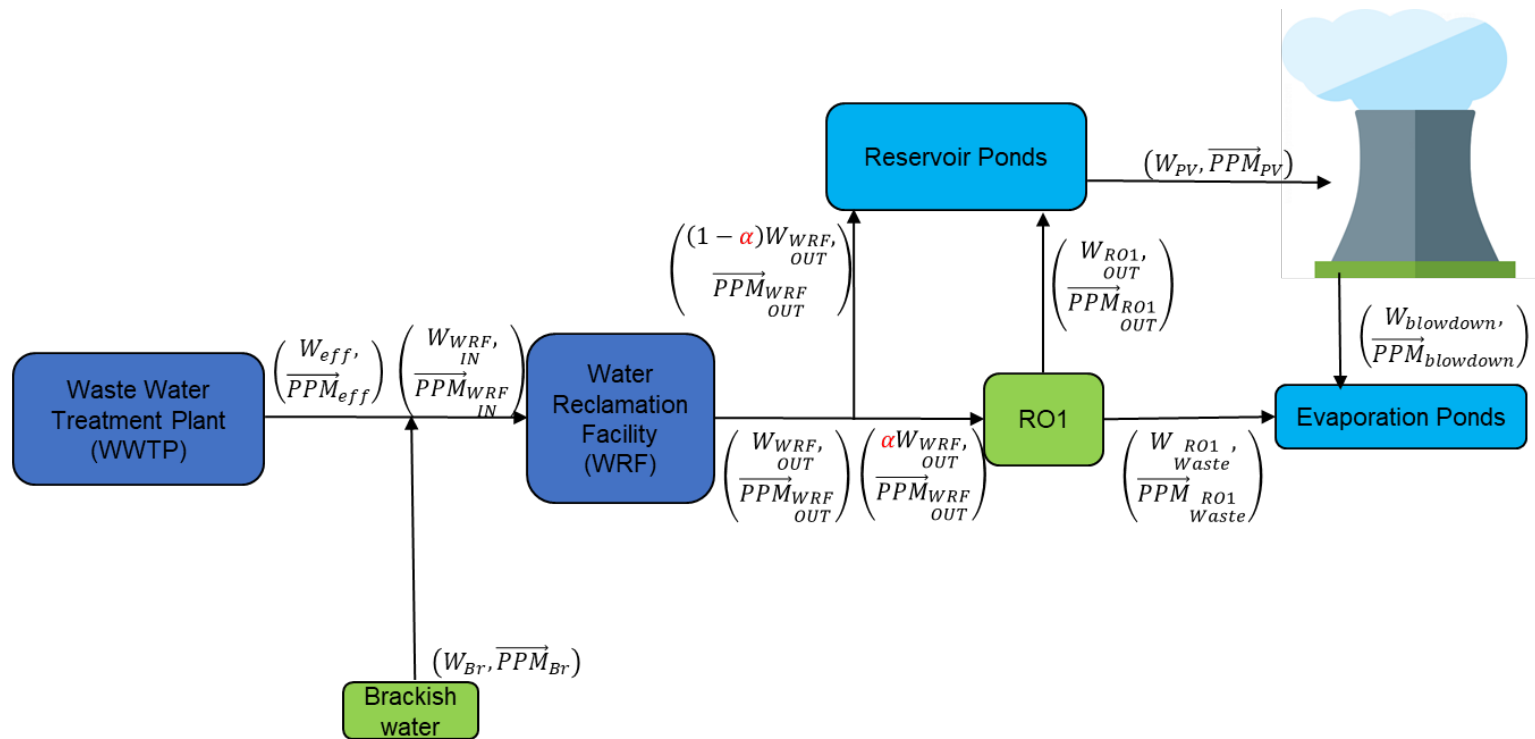

## Case 0: Status Quo

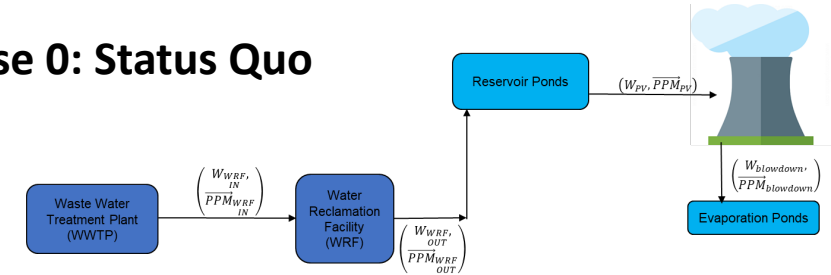

## Case 2: Desalination for Plant Cooling plus Potable Water

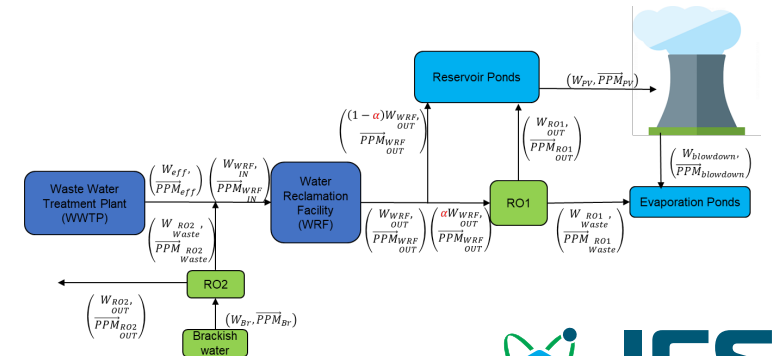

# Potential Scenarios

## Case 2: Desalination for Plant Cooling plus Potable Water

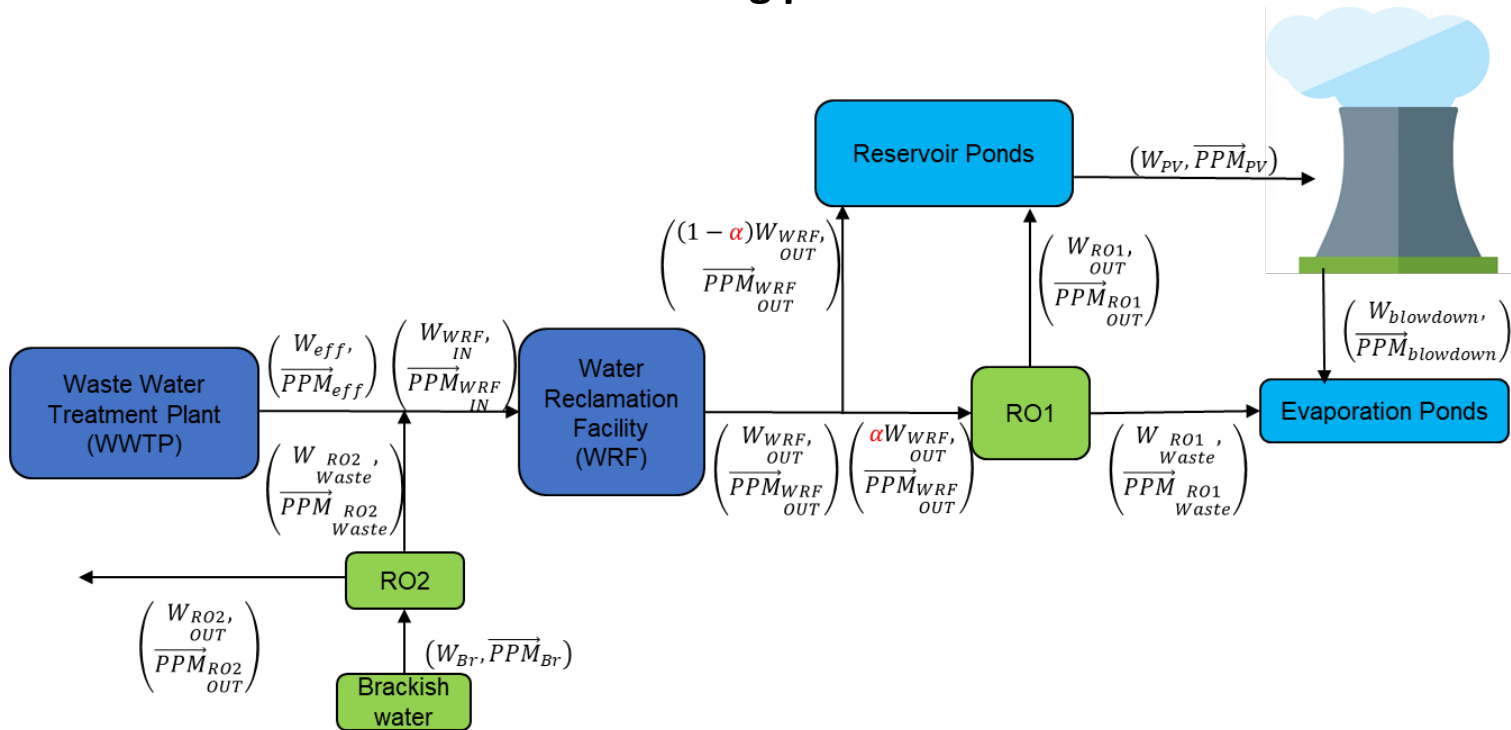

## Case 0: Status Quo

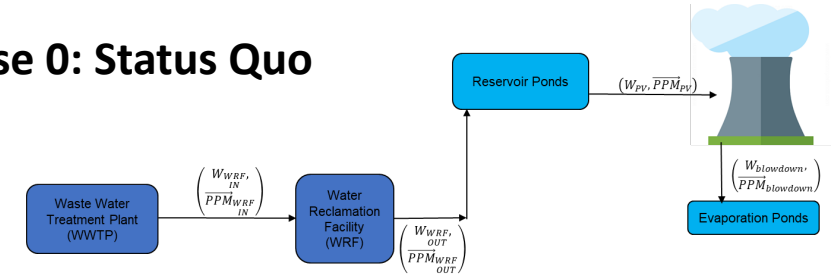

## Case 1: Desalination for Plant Cooling

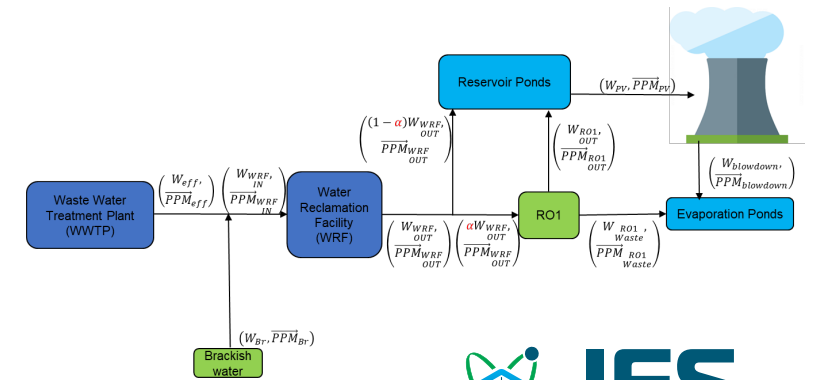

# Analysis shows economic feasibility of implementing onsite desalination at Palo Verde Generating Station

- Results demonstrated to industry partners onsite desalination (RO1) was unnecessary
- Demonstrated to maximize profits RO2 could be built larger given regional water demands
  - The primary constraint on low-cost water is creating larger effluent ponds to store excess brackish water

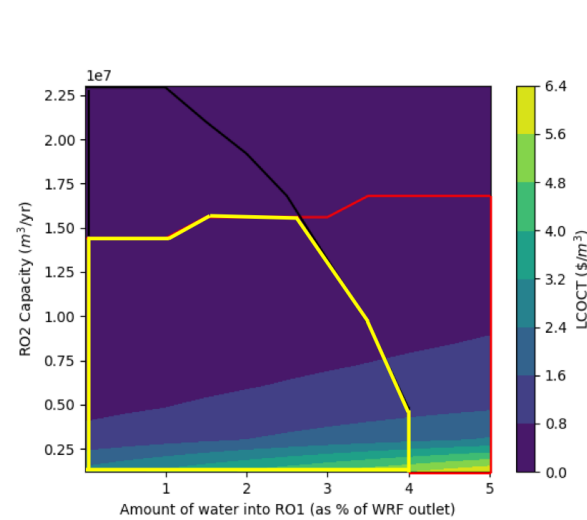

Brackish water 0.0 m³/yr (0 AF/yr).

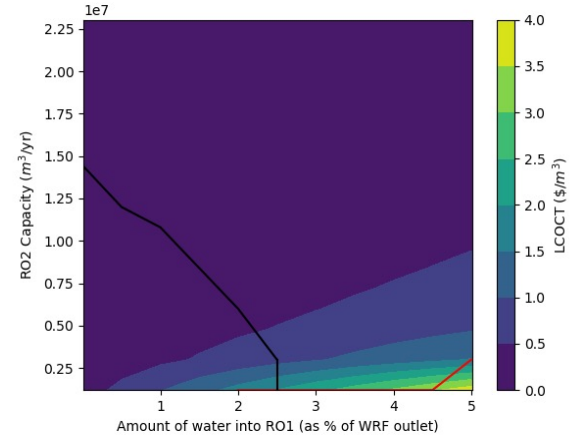

Brackish water 1.9e7 m³/yr (15500 AF/yr).

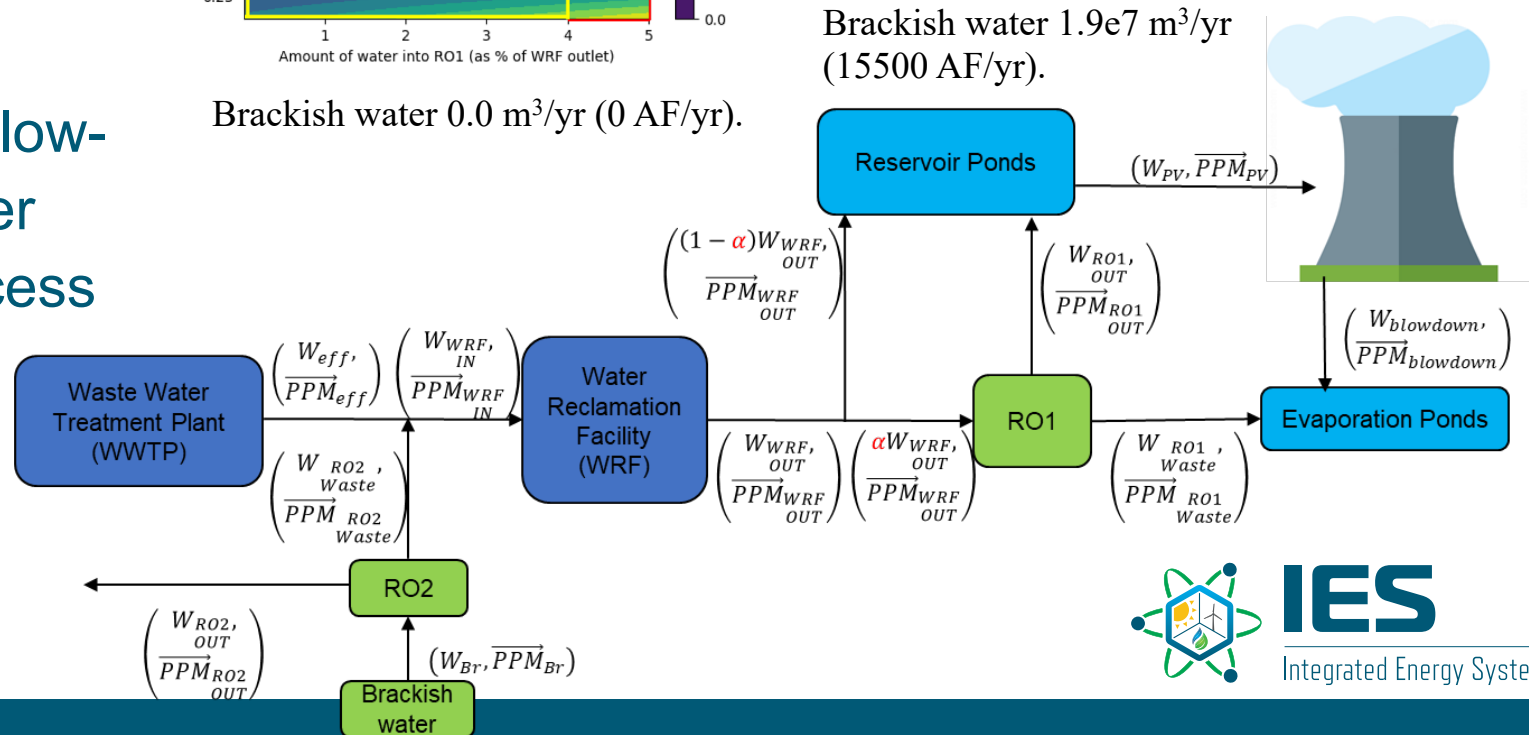

# Exelon Case Study 2019 – Hydrogen Production coupled with an Existing LWR

# Example: Multiple Generators for Hydrogen Production

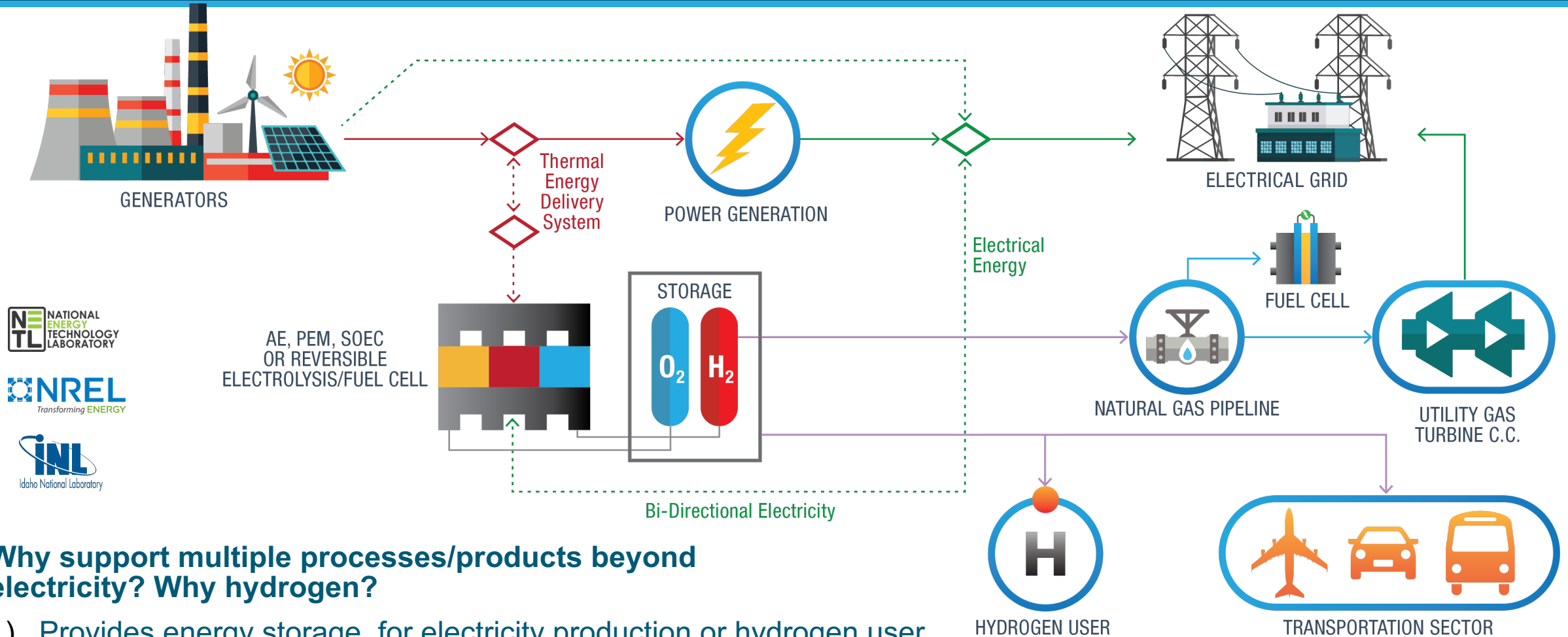

## Why support multiple processes/products beyond electricity? Why hydrogen?

- 1) Provides energy storage, for electricity production or hydrogen user (e.g., chemicals and fuels synthesis, steel manufacturing, ammonia-based fertilizers)
- 2) Provides second source of revenue to the generator
- 3) Provides opportunity for grid services, including reserves and grid regulation





# Example: Disruptive potential of nuclear produced hydrogen

- Collaboration between INL, ANL, NREL, Exelon, and Fuel Cell Energy
- **Goal:** Evaluate the potential of using existing nuclear plants to make hydrogen via high temperature steam electrolysis (HTSE) in parallel to grid electricity to enhance LWR economics
- **Approach:** Techno-economic analysis of HTSE process in selected operating modes and market conditions

- Electricity only (business as usual)
- Dynamic H<sub>2</sub> production (with H<sub>2</sub> storage to enable variable electricity and H<sub>2</sub> dispatch)

- **Assumptions**

- HTSE does not thermally cycle
- Dedicated H<sub>2</sub> transport pipelines
- No subsidies for avoided emissions
- Ancillary services market not considered
- H<sub>2</sub> demand must always be met

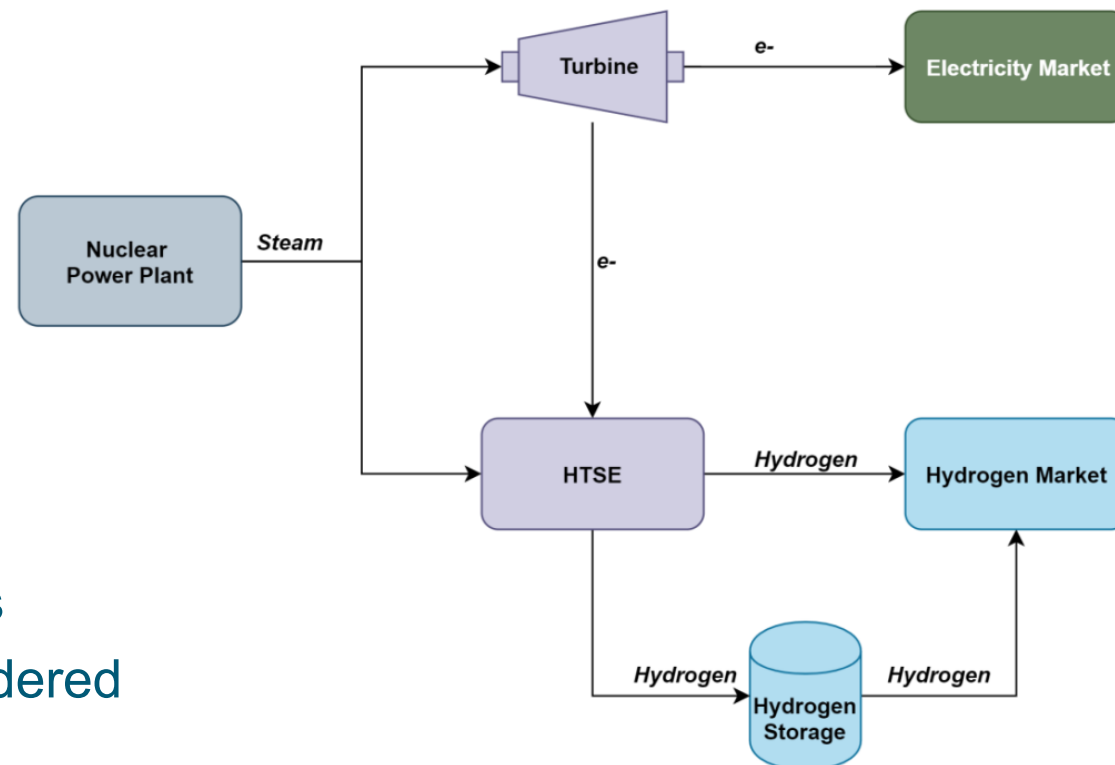

# Example: Disruptive potential of nuclear produced hydrogen

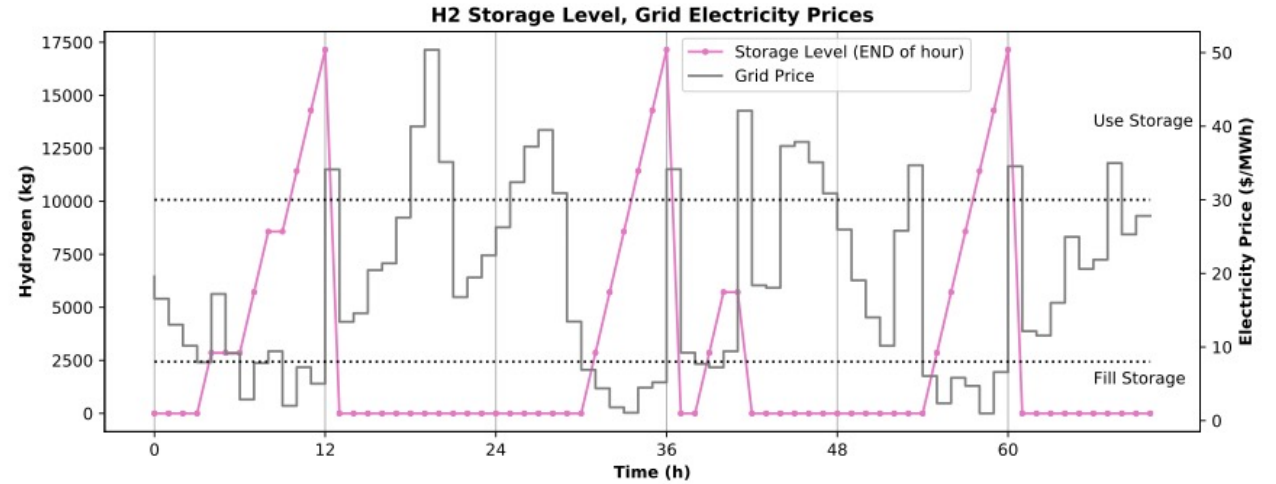
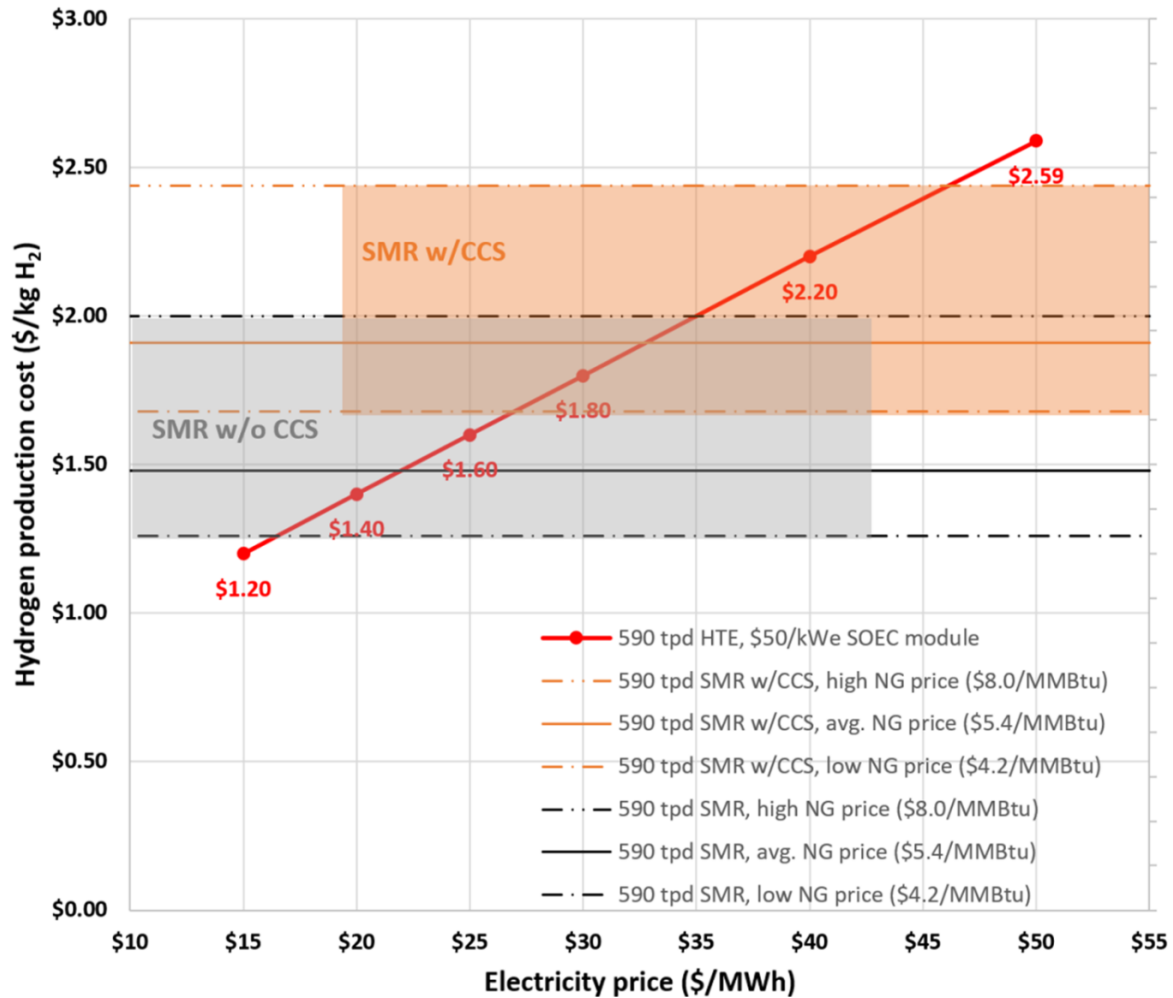

- Analysis tools used to determine optimal dispatch of electricity to meet grid demand (high grid prices) or to produce H<sub>2</sub> (low grid prices)
- H<sub>2</sub> is alternate stored or dispatched from storage to ensure the H<sub>2</sub> market demand is also met at all times

LWR-HTSE LCOH as a function of electricity price compared to the SMR plant (with and without carbon capture sequestration [CCS]) LCOH with low, baseline, and high natural gas pricing. 18

# Example: Disruptive potential of nuclear produced H<sub>2</sub>

- **Results**

- Low grid pricing → hydrogen is more profitable
- High grid pricing → sale to the grid is more profitable
- H<sub>2</sub> storage provides flexibility in plant operations, ensures that all demands are met
- H<sub>2</sub> off-take satisfies demand across steel manufacturing, ammonia and fertilizer production, and fuel cells for transportation
- Analysis results suggest a possible revenue increase of **\$1.2 billion (\$2019)** over a 17-year span
- **Outcome:** Award from the DOE EERE Hydrogen & Fuel Cell Technologies Office with joint Nuclear Energy funding for follow-on work and low temperature electrolysis demonstration at Exelon Nine-Mile Point plant; anticipate hydrogen production ~Fall 2022.
- **Full report:** [Evaluation of Hydrogen Production Feasibility for a Light Water Reactor in the Midwest \(INL/EXT-19-55395\)](#)

*Nine Mile Point  
Nuclear Power Plant  
LTE/PEM Vendor*



# Nuclear-H<sub>2</sub> production demonstration projects

- **Constellation (Exelon): Nine-Mile Point NPP**

- 1 MWe Low Temperature Electrolysis (LTE)/PEM, nel hydrogen
- Using “house load” power
- PEM skid testing underway at NREL
- H<sub>2</sub> production beginning ~October 2022



- **Energy Harbor: Davis-Besse NPP**

- 1-2 MWe LTE/PEM Vendor 2
- Power provided by completing plant upgrade with new switch gear at the plant transmission station
- Installation to be made at next plant outage
- Contract start October 2021; H<sub>2</sub> production ~2023/24



- **Xcel Energy: Prairie Island NPP**

- 150 kWe High Temperature Electrolysis (HTE)/SOEC Vendor 1
- Tie into plant thermal line engineering is being planned
- Design complete Q4 2022; Installation, testing complete Q1 2024



- **APS/PNW Hydrogen: Palo Verde Generating Station**

- 15-20 MWe LTE H<sub>2</sub> production, ~6-8 tons H<sub>2</sub>/day
- Co-locate H<sub>2</sub> production at the site of use
- H<sub>2</sub> storage + H<sub>2</sub> to gas peaking turbines (50%), syngas pilot
- H<sub>2</sub> production expected early 2024



*Nine Mile Point Nuclear Power Plant LTE/PEM, nel hydrogen*



*Davis-Besse Nuclear Power Plant LTE-PEM Vendor 2*



*Thermal & Electrical Integration at Xcel Energy Prairie Island NPP HTE/Vendor 1*

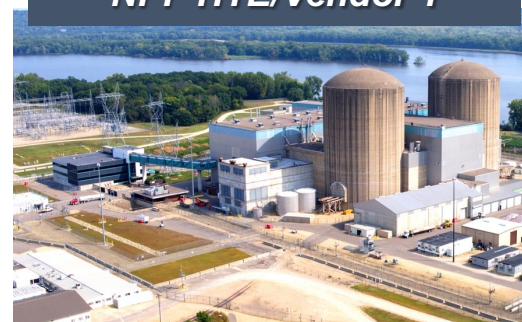

*Palo Verde Gen Station Hydrogen Production for Combustion and Synthetic Fuels*



# Advanced reactor IES case studies (FY22)

- **Thermal energy storage:** Utilization of thermal energy storage to support electrical markets and/or industrial integration
- **Synthetic fuel production:** Nuclear heat and steam to produce hydrogen; then, as a feedstock, the hydrogen is used in conjunction with a CO<sub>2</sub> source to produce various high value synthetic fuels via the Fischer-Tropsch process
- **Carbon conversion:** Nuclear heat and steam to convert coal, as a feedstock, into valuable products for a variety of carbon markets

# Nuclear–Thermal Energy Storage Case Study

**Goal:** Demonstrate the economic opportunity and safe operation of coupling advanced nuclear reactors with thermal energy storage

## Primary Questions:

### 1. Coupling

- Current thermal storage technology options
- Advanced reactor options
- What systems work best together?

### 2. Economics: Which markets have the most opportunity?

- Electricity
- Ancillary products
- Constrained grids

### 3. Control

- How do we safely couple and control the units?
- Dispatch Optimization

## Note:

Nuclear industry engagement ongoing with multiple vendors to inform case selection

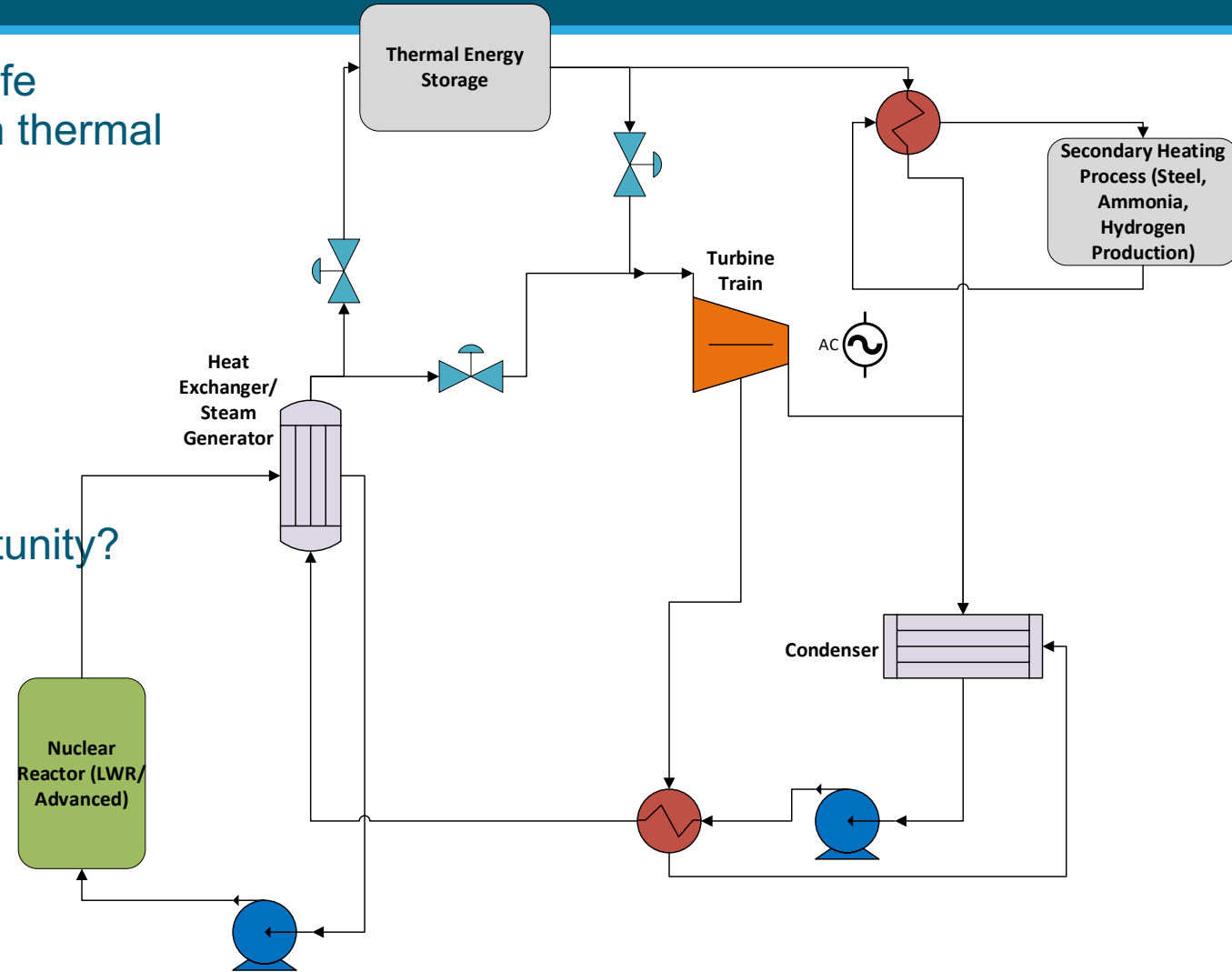

Potential representation of nuclear coupled thermal energy storage

# Nuclear–Carbon Conversion Case Study

**Goal:** Use an advanced reactor to generate steam, heat, and electricity for a coal conversion plant.

- 1) Dry coal and drive off as much mercury as possible
- 2) Mechanical process to fracture the coal and separate mineral matter
- 3) Pyrolysis
- 4) Oil/gas processing
- 5) Syngas refining
  - Methanol
  - Alcohols
  - Polymers

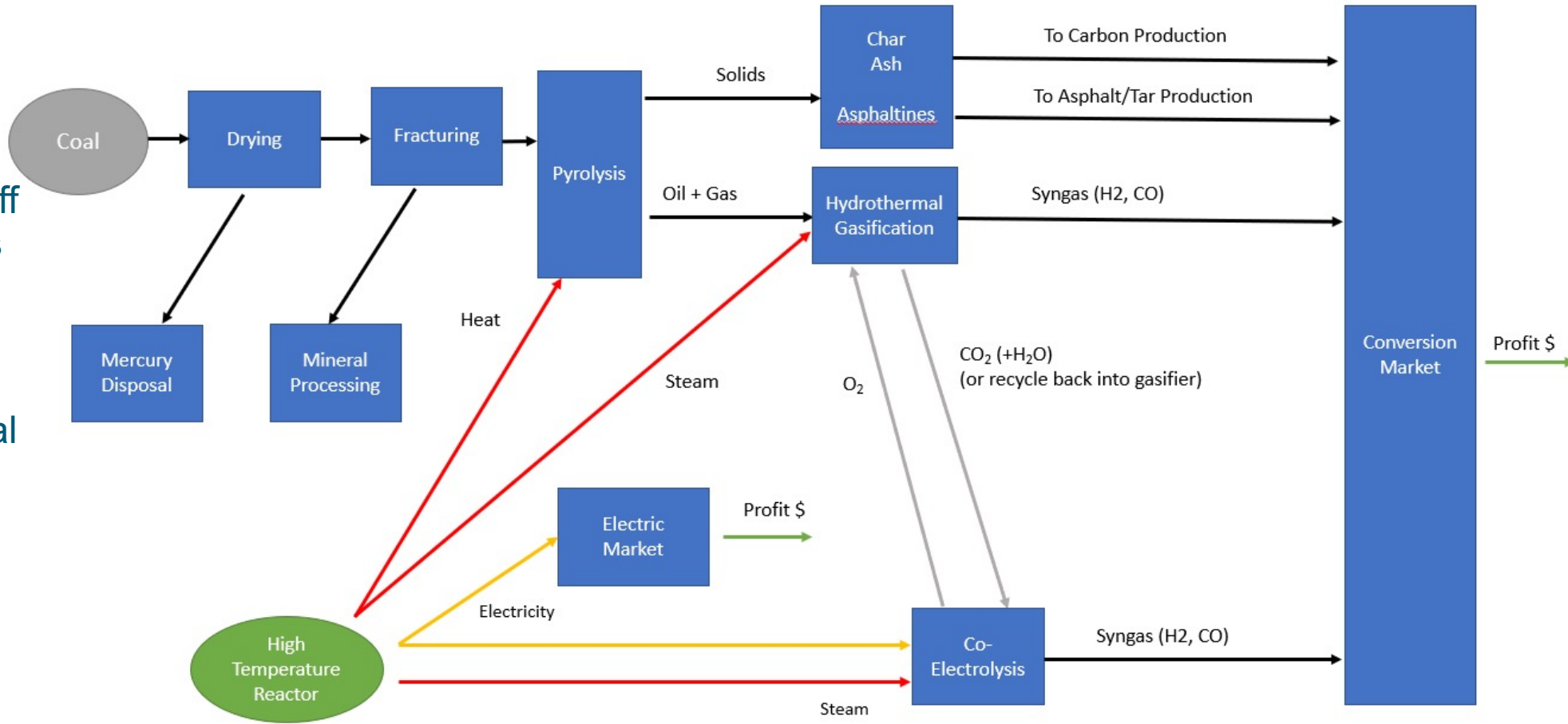

Representative coal conversion process

# Nuclear–Synthetic Fuels Production

**Goal:** Demonstrate the economic potential of using advanced nuclear reactors for synthetic fuels creation.

## Primary Questions

**1. Economics:** Proper distribution of products to minimize economic risk.

- Electricity sales
- Ancillary product sales
- Capacity sizing optimization
- Market participation

**2. Control**

- Coupling and control of the units
- Dispatch optimization

## Outcomes

- Optimized advanced reactor/synthetic fuel process
- Demonstration of proper coupling mechanisms with selected advanced reactors

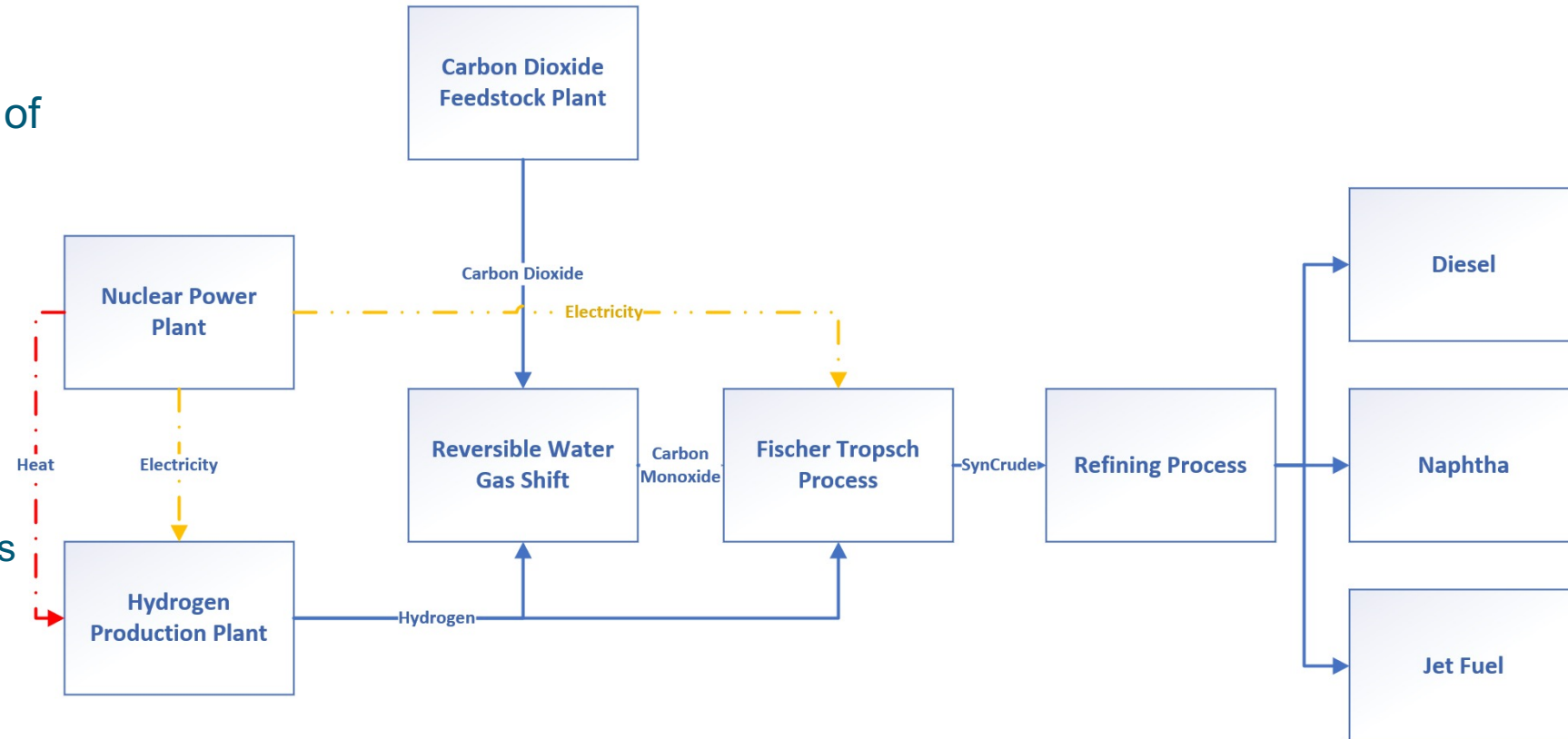

Representation of nuclear coupled synthetic fuel production



## **Experimental evaluation:**

Model validation, technology demonstration,  
performance characterization, control system  
development

# Dynamic Energy Transport and Integration Laboratory (DETAIL) for electrically heated testing of integrated systems

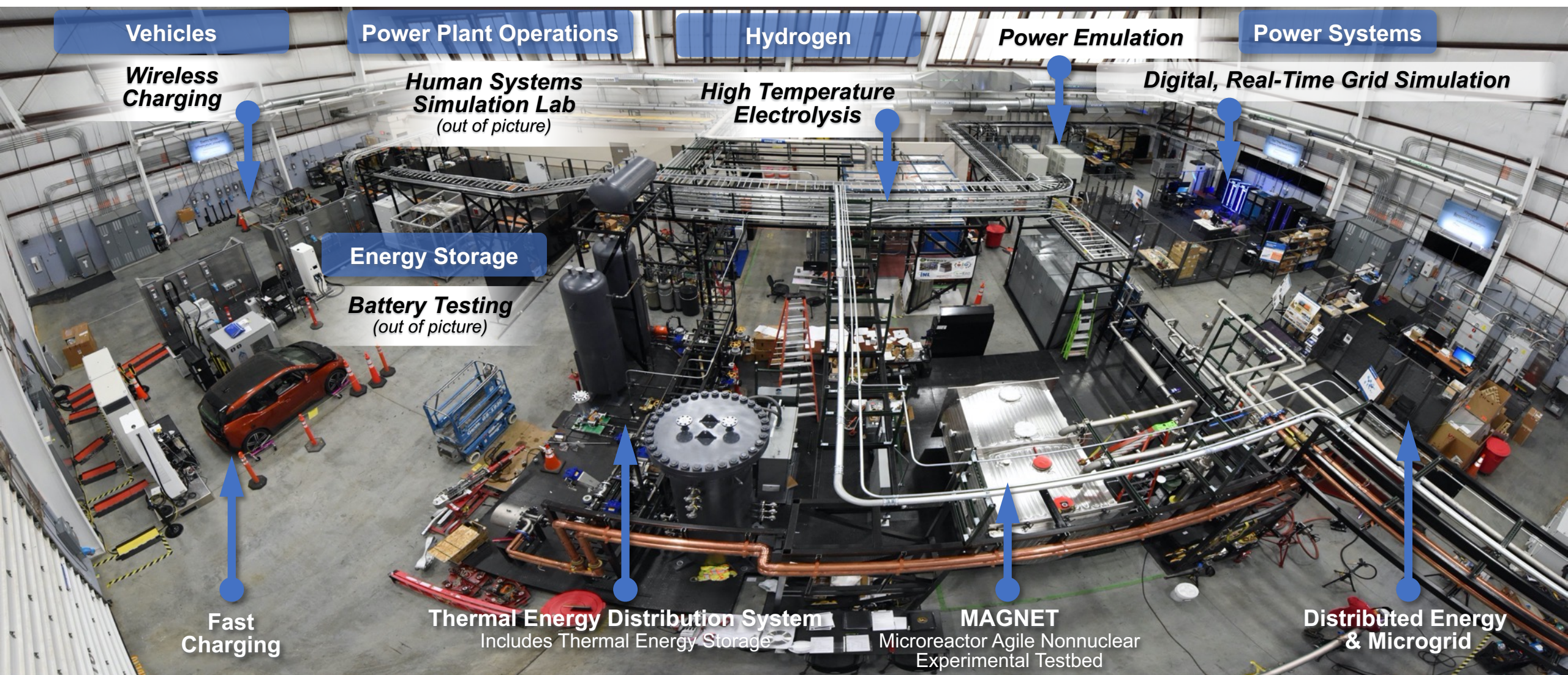

Vehicles

Wireless Charging

Fast Charging

Power Plant Operations

Human Systems Simulation Lab  
(out of picture)

Energy Storage

Battery Testing  
(out of picture)

Thermal Energy Distribution System  
Includes Thermal Energy Storage

Hydrogen

High Temperature Electrolysis

Power Emulation

MAGNET  
Microreactor Agile Nonnuclear  
Experimental Testbed

Power Systems

Digital, Real-Time Grid Simulation

Distributed Energy & Microgrid

# DETAIL enables cross-complex laboratory connections

**ARIES**

IESS at Flatirons Campus



**NREL**  
Transforming ENERGY

**NEL** NATIONAL ENERGY TECHNOLOGY LABORATORY

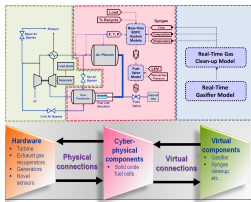

**Power Hardware and Grid-in-the-Loop**

**Thermal Energy Generation and Transport**

**Human-in-the-Loop**

**Hydrogen and other Flexible Industrial Processes**



# National Reactor Innovation Center (NRIC) advanced reactor testing infrastructure

- Goal: Demonstrate two advanced reactors by 2025
- Strategy:
  - Repurpose two facilities at INL and establish two test beds to provide confinement for reactors to go critical for the first time
  - Build/establish testing infrastructure for fuels and components
- Capabilities:
  - NRIC DOME (Demonstration of Microreactor Experiments)
    - Advanced Microreactors up to 20 MWth
    - High-Assay Low-Enriched Uranium (HALEU) fuels < 20%
  - NRIC LOTUS (Laboratory for Operations and Testing in the US)
    - Up to 500 kWth experimental reactors
    - Safeguards category one fuels
  - Experimental Infrastructure
    - Molten Salt Thermophysical Examination Capability
    - Helium Component Test Facility



*Anticipate initial reactor testing in ~2024.  
Flexible testbed to support testing of  
multiple reactor concepts using the same  
infrastructure ~annually.*

*For more information on NRIC and to download resources, see <https://nric.inl.gov/>.*



# Idaho National Laboratory



[WWW.INL.GOV](http://WWW.INL.GOV)